

6' Curve Table Top Extra Thin Frame



Picture shows graphic front panel Upgrade

Exhibit Kit Includes:

- 1 - 2x2 Lite Curve Extra Thin Pop Up Frame
- 10 - Straight Channel Bars
- 1 - Nylon bag for frame and bars
- 1 - Hard carrying case on wheels with locks
- 1 - Halogen Light 150W with case
- 2 - Fabric Front Panels
- 2 - Fabric End Cap Panels

Upgrades:

- 5' Full Color Graphic Banner velcro Backed
- Graphic Front Panels
- Graphic End Cap Panels

Graphic Mural Size:

- 58.58" x 63" h (1488x1600 mm.) No End Cap
- 90" x 63" h (2288x1600 mm.) With End Cap

DISTRIBUTOR:

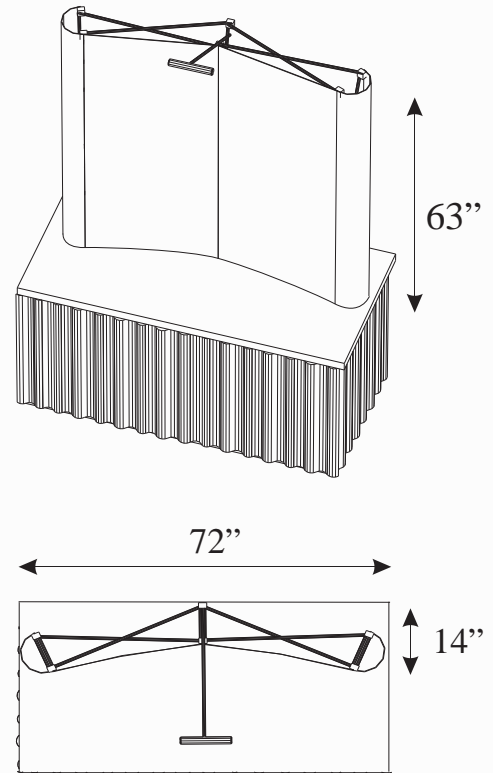

SPECIFICATIONS

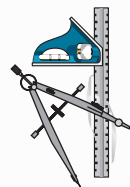

Type: 6' Curve Table Top
Dimensions: 72" x 14" x 63"h
Electrical: 1 Outlet
 150 W Total Power

SET UP



Set Up Time: 10 minutes
with 1 person
Dismantling Time: 8 minutes
with 1 person

SHIPPING



Number of cases: 1

Total Weight: 43 lb (19.35 kg.)

Total Volume: 4.5 cu/ft (0.13 m³)

UPS compatible: yes

